



Interchangeable Pryor steel type and holders provide the complete answer to part numbering and general purpose marking for low and medium volume production.

Durable - made from Sheffield special Tool Steel hardened and tempered to 59-61 Rockwell C for maximum endurance and Nickel Plated to resist rust.

Precise - precision ground blanks and quality control techniques ensure consistent character alignment and depth of impression.

Characters - 9 standard sizes from 1.0mm to 10.0mm designed to give clear and deep impressions.

Sets and Singles - available as single pieces or font sets with or without type holders. Font sets are comprised of 100 letters and figures as shown, conveniently packaged in a storage box.

Holders - 7 standard styles are available. Other sizes are made to order.

Logotypes - custom multicharacter logotypes for constant information can easily be used with Pryor type.

Dimensions

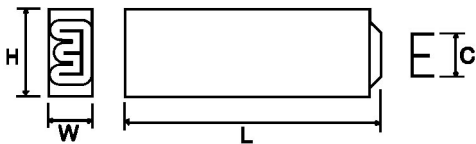

C - Character Size
H - Blank Height
W - Blank Width
L - Blank Length

Type is measured as shown here. Note that all characters have the same width of blank except figure 1 and letter I. These are $\frac{2}{3}$ the width of other characters, except sizes 6mm and 10mm which are all the same width.

Standard Font Composition

CHARACTER	A	B	C	D	E	F	G	H	I	J	K	L	M	N	O	P	Q	R	S	T	U
QUANTITY	3	2	2	2	4	2	2	2	3	2	2	3	2	2	3	2	1	3	3	2	3
CHARACTER	V	W	X	Y	Z	&	/	-	.	,	1	2	3	4	5	6	7	8	9	0	
QUANTITY	1	2	2	1	1	1	2	2	2	2	4	4	3	4	3	3	3	3	3	3	

Detailed Composition of the Standard 100 Piece Font Set

Standard Font Sets and Type Sizes

Size of Character C mm	Size of Blank mm			No. of Spacers in Set	Holder Reference	Holder Capacity
	W	H	L			
1.0	1.6	3.2	15.87	12	H3.2-20	12
1.5	1.6	3.2	15.87	12	H3.2-20	12
2.0	2.0	6.35	19.05	12	H6.35-29	14
2.5	2.4	6.35	19.05	12	H6.35-29	12
3.0	3.2	6.35	19.05	12	H6.35-29	9
4.0	4.0	8.0	19.05	6	H8.0-39	7
5.0	4.8	8.0	19.05	6	H8.0-39	6
6.0	6.4	9.5	19.05	6	H9.6-40	6
10.0	9.5	16.0	25.40	6	H16-57 *	6

* Holder H16-57 is supplied in Font Set only - not available separately.

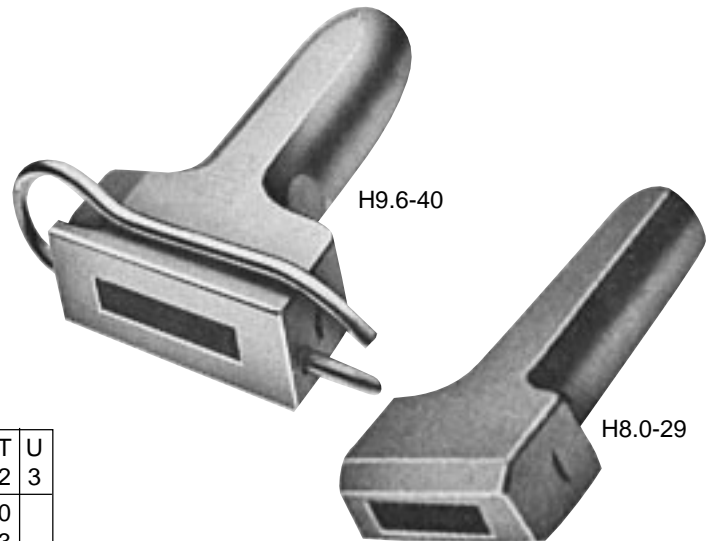

Steel Type Holders: Pryor holders, couple accurate type location, positive locking and durability with rapid changeability and maximum safety to the user. The following sizes are standard and special sizes made to order on request.

Holders for use by hand.

Holder Reference	Capacity, Number of Types, One Row Only									
	Type Size mm									
	1.0	1.5	2.0	2.5	3.0	4.0	5.0	6.0	10.0	
H3.2-20	12	12	-	-	-	-	-	-	-	
H6.35-29	-	-	14	12	9	-	-	-	-	
H6.35-39	-	-	19	16	12	-	-	-	-	
H8.0-39	-	-	-	-	-	9	8	-	-	
H9.6-40	-	-	-	-	-	-	-	6	-	
H16-57 *	-	-	-	-	-	-	-	-	6	

Holder Reference Number: H3.2-20 is a holder with a slot 3.2mm high x 20mm long.