

Quick Change _____ Numbering Head

The Model 80 is ideal for stamping repetitive sequences such as serial numbers, product codes, date codes, etc. The unit wheel is easily changed by rotating the knurled knob. This wheel is indexed for direct sight reading. The remaining wheels are changed by using the convenient spanner wrench. Multiple wheels are held precisely in position by retaining pawls and springs. The wheels are engraved from high grade tool steel and precision heat treated for severe usage. Handshank frames are constructed of heat-treated alloy steel to resist chipping and is vinyl coated to absorb shock when struck with a hammer. Also available with 1" diameter press shank (1 1/4" or 2" long).

Character Sizes: 1/32", 1/16", 3/32", 1/8", 3/16", 1/4"

Number of Wheels: 3, 4, 5, 6, 7, 8, 9, 10

Phone, fax or eMail for a ... **FAST QUOTE**



... Numbering Head



... Model 80

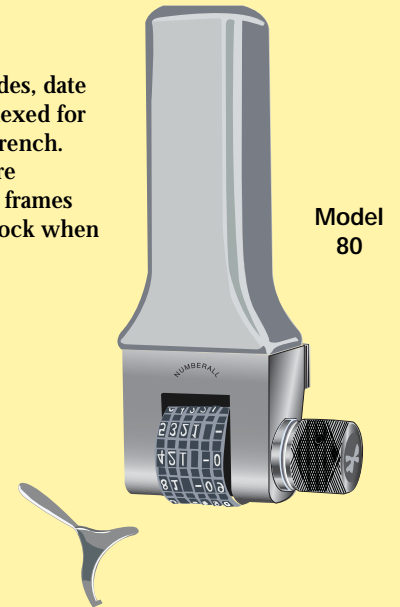

Model 80

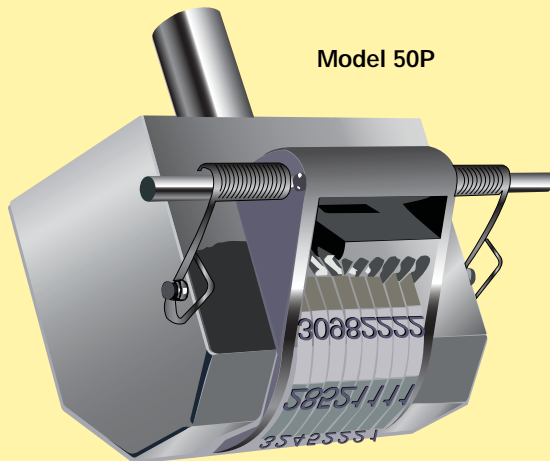

Model 50P

Automatic _____ Numbering Head

The Model 50P represents the industry standard for rapid, accurate, consecutive numbering. Since 1935, the Model 50P has been steadily improved ... we are still supplying parts to units over 30 years old. During the marking sequence, the actuating arms are extended and retracted by an external means to advance the machine to the next consecutive number. The zero suppression feature allows for the omitting of leading zeros. Wheels are manufactured from heavy-duty tool steel and precision heat-treated for long life. Options available to repeat the same number from 2 to 20 times before advancing.

Character Sizes: 1/32", 1/16", 3/32", 1/8", 3/16", 1/4", 3/8"

Number of Wheels: 4, 5, 6, 7, 8, 9, 10

Phone, fax or eMail for a ... **FAST QUOTE**



... Model 50P



... Marking Presses

Rotary Stamps

Single wheel rotary steel hand stamps. All figures on one wheel ... simply change by rotating the wheel. Letters furnished on two wheels. Available in sizes from 1/16" to 3/8". Also available with a 1/2" press shank.



... Rotary Stamps

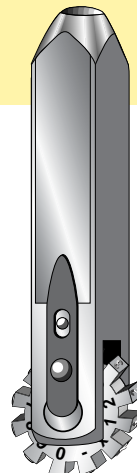

Character Sizes:

1/16", 3/32", 1/8", 5/32", 3/16", 1/4", 5/16", 3/8"

Sets: 12 Character Figure Set
14 Character Letter Set (A-M)
14 Character Letter Set (N-Z)

Rotary Date Stamp
Multi-Wheel Numbering Stamps

Phone, fax or eMail for a ... **FAST QUOTE**